



HEIDENHAIN



Product Information

LC 195 P

LC 495 P

Absolute Linear Encoders
with Panasonic Interface

April 2016



Specifications	LC 195P
Measuring standard Coefficient of linear expansion	DIADUR glass scale with absolute track and incremental track, grating period 20 µm $\alpha_{\text{therm}} \approx 8 \times 10^{-6} \text{ K}^{-1}$
Accuracy grade*	±3 µm up to 3040 mm measuring length; ±5 µm
Measuring length ML* in mm	140 240 340 440 540 640 740 840 940 1040 1140 1240 1340 1440 1540 1640 1740 1840 2040 2240 2440 2640 2840 3040 3240 3440 3640 3840 4040 4240
Functional safety For applications up to	–
PFH	–
Safe position	–
	<i>Mechanical connection: fault exclusions for loosening of the housing and scanning unit (see Linear Encoders for Numerically Controlled Machine Tools catalog)</i>
Interface	Panasonic serial interface
Ordering designation	Pana01
Measuring step <i>With ±3 µm</i> <i>With ±5 µm</i>	0.001 µm 0.010 µm
Clock frequency (calculating time t_{cal})	–
Electrical connection	Separate adapter cable (1 m/3 m/6 m/9 m) connectable at either end of mounting block
Cable length	≤ 50 m
Voltage supply	DC 3.6 V to 14 V
Power consumption (max.)	3.6 V: ≤ 1.1 W; 14 V: ≤ 1.3 W
Traversing speed	≤ 180 m/min (max. acceleration ≤ 100 m/s ²)
Required moving force	≤ 4 N
Vibration 55 Hz to 2000 Hz <i>affecting the</i> Shock 11 ms	<i>Housing: ≤ 200 m/s² (EN 60068-2-6)</i> <i>Scanning unit: ≤ 200 m/s² (EN 60068-2-6)</i> ≤ 300 m/s ² (EN 60068-2-27)
Operating temperature	0 °C to 50 °C
Protection EN 60529 ¹⁾	IP 53 when installed according to instructions in the brochure, IP 64 with sealing air from DA 400
Mass	0.55 kg + 2.9 kg/m measuring length

* Please select when ordering

¹⁾ The LC must be protected in the application from the intrusion of particles and liquids

LC 400 series

Absolute linear encoders with slimline scale housing

- For limited installation space

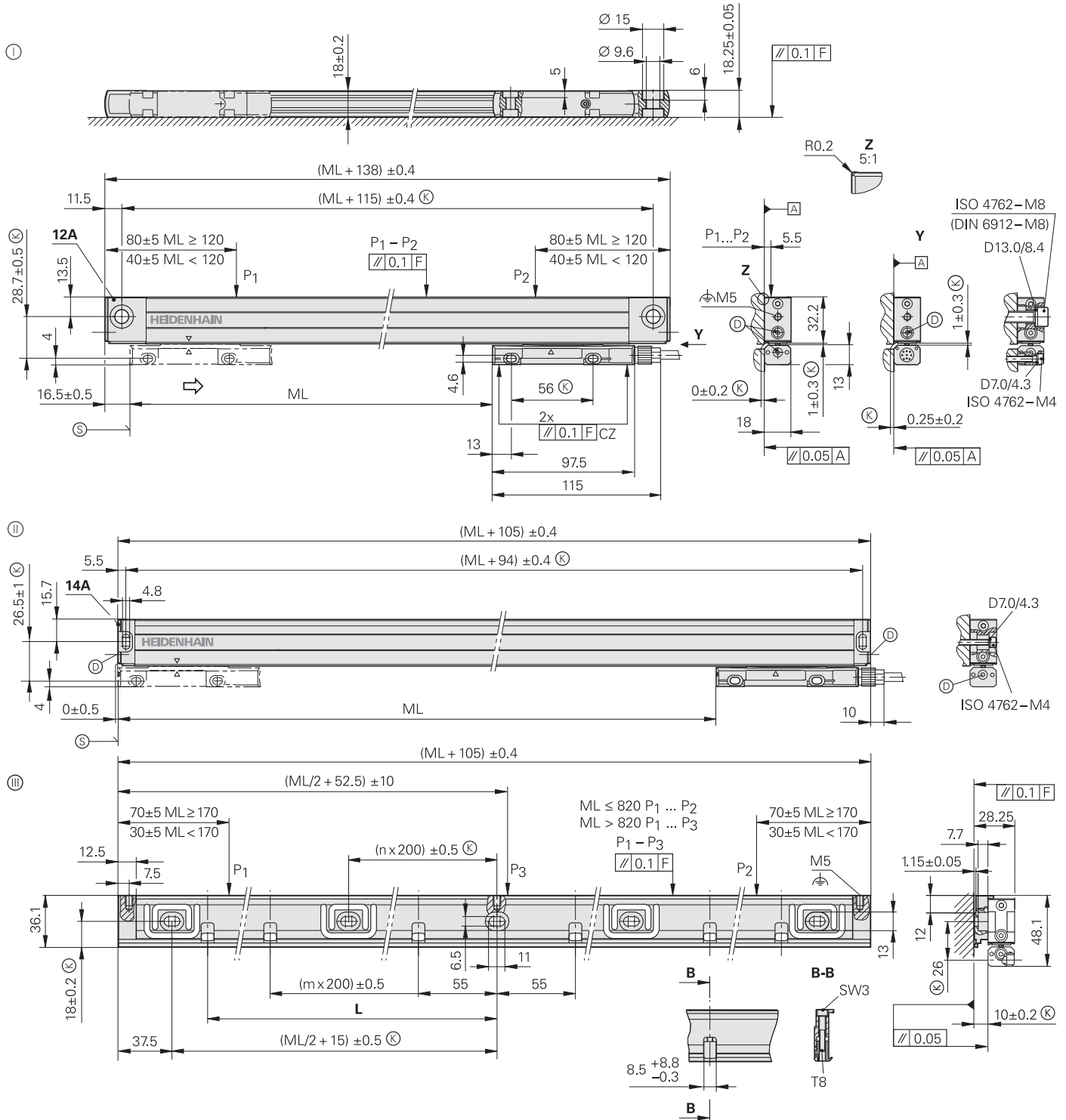

ML	70	120	170	220	270	320	370	420	470	520	570	620	670	720	770	820	920	1020	1140	1240	1340	1440	1540	1640	1740	1840	2040
L	37.5	55	75	100	115	140	175	200	225	250	275	300	325	350	375	400	450	500	555	610	655	710	760	810	855	910	1010

mm

 Tolerancing ISO 8015
 ISO 2768 - m H
 < 6 mm: ± 0.2 mm

- ⊖ = End block 12A; mounting with and without mounting spar
- ⊕ = End block 14A; for mounting with mounting spar (specifications are restricted if attached directly with M4 screws)
- ⊗ = MSL 41 mounting spar
- F = Machine guideway
- P = Gauging points for alignment
- ⊙ = Required mating dimensions
- ⊚ = Compressed air inlet
- ⊙ = Beginning of measuring length ML (= 20 mm absolute)
- ⇒ = Direction of scanning unit motion for output signals in accordance with interface description







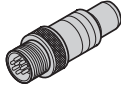

Specifications	LC 495P
Measuring standard Coefficient of linear expansion	DIADUR glass scale with absolute track and incremental track, grating period 20 µm $\alpha_{\text{therm}} \approx 8 \times 10^{-6} \text{ K}^{-1}$ (mounting mode ☉/☉); <i>with mounting spar</i> : $\alpha_{\text{therm}} \approx 9 \times 10^{-6} \text{ K}^{-1}$ (mounting mode ☉)
Accuracy grade*	± 3 µm, ± 5 µm
Measuring length ML* in mm	Mounting spar* or clamping elements* up to ML 1240 optional, necessary as of ML 1340 70 120 170 220 270 320 370 420 470 520 570 620 670 720 770 820 920 1020 1140 1240 1340 1440 1540 1640 1740 1840 2040
Functional safety For applications up to	–
PFH	–
Safe position	–
	<i>Mechanical connection</i> : fault exclusions for loosening of the housing and scanning unit (see <i>Linear Encoders for Numerically Controlled Machine Tools</i> catalog)
Interface	Panasonic serial interface
Ordering designation	Pana01
Measuring step <i>With ±3 µm</i> <i>With ±5 µm</i>	0.001 µm 0.010 µm
Clock frequency (calculating time t_{cal})	–
Electrical connection	Separate adapter cable (1 m/3 m/6 m/9 m) connectable on mounting block
Cable length	≤ 50 m
Voltage supply	DC 3.6 V to 14 V
Power consumption (max.)	3.6 V: ≤ 1.1 W; 14 V: ≤ 1.3 W
Traversing speed	≤ 180 m/min (max. acceleration in measuring direction ≤ 100 m/s ²)
Required moving force	≤ 5 N
Vibration 55 Hz to 2000 Hz <i>affecting the</i>	<i>Scanning unit</i> : ≤ 200 m/s ² (EN 60068-2-6) <i>Housing without mounting spar</i> : ≤ 100 m/s ² (EN 60068-2-6) <i>Housing with mounting spar,</i> <i>cable outlet at right</i> : ≤ 150 m/s ² , <i>left</i> : ≤ 100 m/s ² (EN 60068-2-6)
Shock 11 ms	≤ 300 m/s ² (EN 60068-2-27)
Operating temperature	0 °C to 50 °C
Protection EN 60529 ¹⁾	IP 53 when installed according to instructions in the brochure, IP 64 with sealing air from DA 400
Mass	<i>Encoder</i> : 0.2 kg + 0.55 kg/m measuring length; <i>mounting spar</i> : 0.9 kg/m

* Please select when ordering

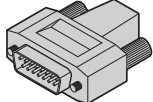
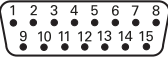
¹⁾ The LC must be protected in the application from the intrusion of particles and liquids

Panasonic pin layout

8-pin coupling, M12					15-pin D-sub connector				
									
10-pin Panasonic connector									
	Power supply				Absolute position values				
	8	2	5	1	3	4	7	6	
	4	12	2	10	5	13	8	15	
	1	1	2	2	-	-	3	4	
	U_P	Sensor U _P	0V	Sensor 0V	Vacant ¹⁾	Vacant ¹⁾	Request Data	Request Data	
	Brown/Green	Blue	White/Green	White	Gray	Pink	Violet	Yellow	

Cable shield connected to housing; **U_P** = Power supply voltage

Sensor: The sensor line is connected in the encoder with the corresponding power line.





Vacant pins or wires must not be used.

¹⁾ Required for adjustment/inspection by PWM 20

Electrical connection

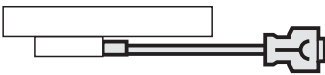
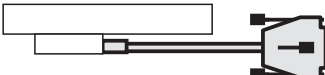

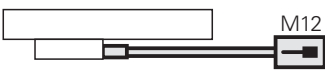

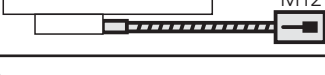
Panasonic

Adapter cables

		Cable Ø	ID
Adapter cable with Panasonic connector, 10-pin		Ø 6 mm [2 x (2 x 0.09 mm ²) + 2 x (2 x 0.14 mm ²)]	1160261-xx
Adapter cable with D-sub connector, 15-pin		Ø 4.5 mm [1 x (4 x 0.09 mm ²) + 4 x 0.14 mm ²]	1158342-xx
Adapter cable with D-sub connector, 15-pin		Ø 10 mm [1 x (4 x 0.09 mm ²) + 4 x 0.14 mm ²]	1123096-xx
Adapter cable with M12 coupling (male) 8-pin		Ø 4.5 mm [1 x (4 x 0.09 mm ²) + 4 x 0.14 mm ²]	1036537-xx
Adapter cable with M12 coupling (male) 8-pin		Ø 6 mm [2 x (2 x 0.09 mm ²) + 2 x (2 x 0.14 mm ²)]	1036547-xx
Adapter cable in metal armor with M12 coupling (male) 8-pin		Ø 10 mm [1 x (4 x 0.09 mm ²) + 4 x 0.14 mm ²]	1122879-xx

Available cable lengths: 1 m/3 m/6 m/9 m

Connecting cables

		Cable Ø	ID
Complete with M12 connector (female), 8-pin, and coupling (male)		Ø 6 mm [2 x (2 x 0.09 mm ²) + 2 x (2 x 0.14 mm ²)]	1036372-xx
Complete with M12 connector (female), 8-pin, and coupling (male)		Ø 8 mm [2 x (2 x 0.24 mm ²) + 2 x (2 x 0.35 mm ²)]	745894-xx
Complete with M12 connector (female), 8-pin, and Panasonic connector, 10-pin		Ø 6 mm [2 x (2 x 0.09 mm ²) + 2 x (2 x 0.14 mm ²)]	1160268-xx
Complete with M12 connector (female), 8-pin, and D-sub connector, 15-pin		Ø 6 mm [2 x (2 x 0.09 mm ²) + 2 x (2 x 0.14 mm ²)]	1036526-xx
Complete with M12 connector (female), 8-pin, and D-sub connector, 15-pin		Ø 8 mm [2 x (2 x 0.24 mm ²) + 2 x (2 x 0.35 mm ²)]	1129753-xx

HEIDENHAIN

DR. JOHANNES HEIDENHAIN GmbH

Dr.-Johannes-Heidenhain-Straße 5

83301 Traunreut, Germany

☎ +49 8669 31-0

FAX +49 8669 32-5061

E-mail: info@heidenhain.de

www.heidenhain.de

For more information

- Linear Encoders for Numerically Controlled Machine Tools catalog