

ECN/EQN 1300 series

Absolute rotary encoders

- 07B stator coupling with anti-rotation element for axial mounting
- Taper shaft 65B
- Encoders available with functional safety
- Fault exclusion for rotor and stator coupling as per EN 61800-5-2 possible

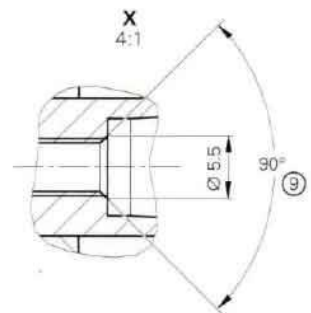
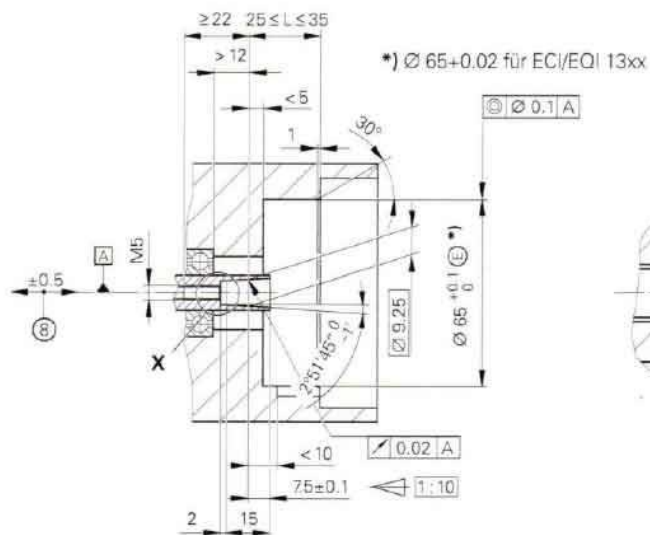
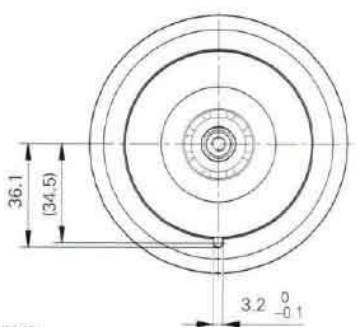
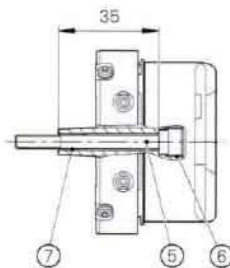
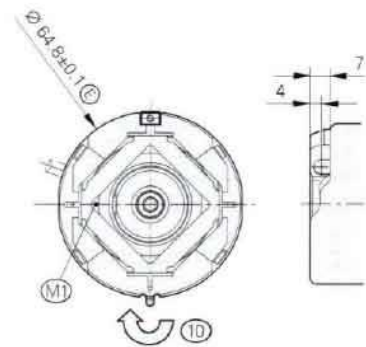
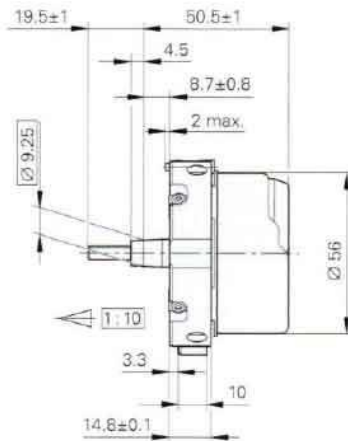
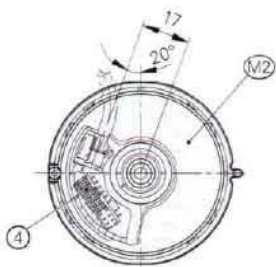
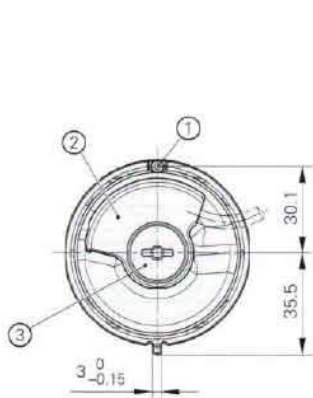

mm
 Tolerancing ISO 8015
 ISO 2768 - m H
 < 6 mm: ±0.2 mm

- ⊠ = Bearing of mating shaft
- ⊗ = Required mating dimensions
- ⊙ = Measuring point for operating temperature
- ⊕ = Clamping screw for coupling ring, width A/F 2. Tightening torque: 1.25–0.2 Nm
- ⊖ = Die-cast cover
- ⊗ = Screw plug, width A/F 3 and 4. Tightening torque: 5 + 0.5 Nm
- ⊙ = PCB connector
- ⊕ = Self-locking screw M5 x 50 DIN 6912 SW4 (for use in safety-related applications: with materially bonding anti-rot. lock), tightening torque 5+0.5 Nm
- ⊗ = M10 back-off thread
- ⊖ = M6 back-off thread
- ⊙ = Compensation of mounting tolerances and thermal expansion, no dynamic motion permitted
- ⊕ = Direction of shaft rotation for output signals as per the interface description

	Absolute			
	ECN 1313	ECN 1325	EQN 1325	EQN 1337
Interface	EnDat 2.2			
Ordering designation	EnDat01	EnDat22	EnDat01	EnDat22
Position values/revolution	8192 (13 bits)	33554432 (25 bits)	8192 (13 bits)	33554432 (25 bits)
Revolutions	–		4096 (12 bits)	
Elec. permissible speed/ Deviation ²⁾	512 lines: 5000 min ⁻¹ /± 1 LSB 12000 min ⁻¹ /± 100 LSB 2048 lines: 1500 min ⁻¹ /± 1 LSB 12000 min ⁻¹ /± 50 LSB	15000 min ⁻¹ (for continuous position value)	512 lines: 5000 min ⁻¹ /± 1 LSB 12000 min ⁻¹ /± 100 LSB 2048 lines: 1500 min ⁻¹ /± 1 LSB 12000 min ⁻¹ /± 50 LSB	15000 min ⁻¹ (for continuous position value)
Calculation time t_{cal} Clock frequency	≤ 9 μs ≤ 2 MHz	≤ 7 μs ≤ 16 MHz	≤ 9 μs ≤ 2 MHz	≤ 7 μs ≤ 16 MHz
Incremental signals	~ 1 V _{PP} ¹⁾	–	~ 1 V _{PP} ¹⁾	–
Line count*	512 2048	2048	512 2048	2048
Cutoff frequency –3 dB	2048 lines: ≥ 400 kHz 512 lines: ≥ 130 kHz	–	2048 lines: ≥ 400 kHz 512 lines: ≥ 130 kHz	–
System accuracy	512 lines: ± 60"; 2048 lines: ± 20"			
Electrical connection Via PCB connector	12-pin	Rotary encoder: 12-pin Temp. sensor ³⁾ : 4-pin	12-pin	Rotary encoder: 12-pin Temp. sensor ³⁾ : 4-pin
Voltage supply	3.6 V to 14 V DC			
Power consumption (maximum)	3.6 V: ≤ 0.6 W 14 V: ≤ 0.7 W		3.6 V: ≤ 0.7 W 14 V: ≤ 0.8 W	
Current consumption (typical)	5 V: 85 mA (without load)		5 V: 105 mA (without load)	
Shaft	Taper shaft Ø 9.25 mm; taper 1:10			
Mech. permiss. speed n	≤ 15000 min ⁻¹		≤ 12000 min ⁻¹	
Starting torque	≤ 0.01 Nm (at 20 °C)			
Moment of inertia of rotor	2.6 · 10 ⁻⁶ kgm ²			
Natural frequency of the stator coupling	≥ 1800 Hz			
Permissible axial motion of measured shaft	± 0.5 mm			
Vibration 55 to 2000 Hz Shock 6 ms	≤ 300 m/s ² ⁴⁾ (EN 60068-2-6) ≤ 2000 m/s ² (EN 60068-2-27)			
Max. operating temp.	115 °C			
Min. operating temp.	–40 °C			
Protection EN 60529	IP 40 when mounted			
Weight	≈ 0.25 kg			

* Please select when ordering

¹⁾ Restricted tolerances

Signal amplitude: 0.8 to 1.2 V_{PP}
Asymmetry: 0.05
Amplitude ratio: 0.9 to 1.1
Phase angle: 90° ± 5° elec.
Signal-to-noise ratio E, F: ≥ 100 mV

²⁾ Velocity-dependent deviations between the absolute and incremental signals

³⁾ Evaluation optimized for KTY 84-130

⁴⁾ As per standard for room temperature; for operating temperature: Up to 100 °C: ≤ 300 m/s²;
Up to 115 °C: ≤ 150 m/s²

Functional safety available for ECN 1325 and EQN 1337. For dimensions and specifications see the Product Information document